

THE INTREPID MUSEUM  
PIER 86, NEW YORK, NY

COMBINED HEAT, COOLING AND POWER  
INSTALLATION

NYSERDA MONITORING AND VERIFICATION PLAN

*DRAFT SUBMISSION TO CDH, Rev 2*

April 21, 2014

NYSERDA AGREEMENT NUMBER 22252

Prepared For:

The Intrepid Sea, Air, and Space Museum  
Pier 86  
New York, NY

Prepared By:



**DSM Engineering Associates, P.C.**  
**1363-26 Veterans Highway**  
**Hauppauge, New York 11788**

INTREPID SEA, AIR, AND SPACE MUSEUM  
COMBINED HEAT AND POWER INSTALLATION

**Table of Contents**

THE INTREPID SEA, AIR, AND SPACE MUSUEM CHP SYSTEM DOCUMENTATION: ..... 1

    CHP SYSTEM OVERVIEW ..... 1

        CHP HOT WATER (CHPHW): ..... 2

        CHP-1,2,3: ..... 5

        P-CHPHW-1/2: ..... 5

        HX-HTG: ..... 6

        CHILLER1: ..... 6

        HX-HBR: ..... 7

    CHP OUTPUT UTILIZATION ..... 7

        Thermal Utilization ..... 7

        Electrical Utilization ..... 8

    NYSERDA MONITORING PLAN OVERVIEW: ..... 10

        CHP System Schematic and NYSERDA Monitoring Points : ..... 10

        Data Logger and Data Processing: ..... 10

        Data Processing ..... 22

        Emissions Monitoring ..... 22

ATTACHMENTS ..... 23

## **THE INTREPID SEA, AIR, AND SPACE MUSUEM CHP SYSTEM**

### **DOCUMENTATION:**

#### **CHP SYSTEM OVERVIEW**

The Intrepid CHCP installation is based upon three Tecogen Inverde Ultra package cogeneration units, each of which is rated at 100 kW gross electrical output and 670,000 BTU/Hr (6.7 therms) thermal energy recovered. In addition to the CHP units, the installation consists of the following systems and the equipment and components connected to these systems. The system and equipment descriptions provided here are summary and do not provide detailed discussion of control components or strategies. Detailed discussion of control and operation of the components is provided in the Sequences of Operations (SOO) section of the design documents, provided as a separate attachment file.

Only the CHP systems are included in this document. Other systems/components that are part of the project such as the supplemental heaters and chiller are not included in the NYSERDA monitoring system and are not included in this document.

#### **CHCP System Summaries:**

##### **CHP HOT WATER (CHPHW):**

The CHPHW circulates hot water through the CHP units to recover the CHP unit thermal output and then supply the thermal output to the thermal loads, including excess thermal rejection via the heat balance radiators via the HBR fluid system when necessary. The CHPHW flow rate is seasonal. During the cooling season, the flow rate will be 200 GPM to match the design hot water flow rate for the absorption chiller with a CHPHW supply temperature of 200 °F (CHP units at rated maximum output). Heating season CHPHW flow rate will be reduced to 120 GPM to reduce pumping costs and increase delivered CHPHW temperature to the heating loads (213°F).

Primary CHCPHW flow is maintained by P-CHPHW1 or P-CHPHW2 at the design seasonal flow rates. Each CHP unit is equipped with its own internal CHPHW pump which circulates 30 GPM from the CHPHW return header through the CHP unit heat recovery components and back to the CHPHW supply header. Rated CHPHW temperature out of each CHP unit is 235°F at 30 GPM. CHPHW flow to the CHP units is 90 GPM when all three are in operation and the balance of the CHPHW flow (110 GPM cooling, 40 GPM heating) will pass through the return header to mix with the CHPHW from the CHP units resulting in the CHPHW supply temperatures to loads of 200/213 cooling/heating season.

##### **CHILLED/HOT WATER – CHW:**

The Chilled-Hot Water system provides heated or chilled water (2 pipe, seasonal operation) to the HVAC distribution air handlers throughout the facility.

##### **COOLING TOWER WATER – CTW:**

Cooling tower water transfers heat from the chillers to the cooling towers located on the flight deck during the cooling season.

##### **ELECTRONIC FLUID COOLING – EFC:**

INTREPID SEA, AIR, AND SPACE MUSEUM  
COMBINED HEAT AND POWER INSTALLATION

The CHP units each have inverters that process the CHP generator electrical output to enable parallel operation with the local utility (Con Edison).

**HEAT BALANCE/REJECTION - (HBR):**

The HBR system provides thermal rejection from the CHP hot water system to the heat balance radiators HBR-1,2,3 on the Flight Deck. The CHP units will normally operate in “thermal following” mode – they will automatically reduce output when thermal loads are less than CHP capacity. When necessary to enable standby electrical operation or otherwise desired (demand reduction periods), the CHP units will operate to meet electrical loads and may produce more thermal energy than is needed by the thermal loads. Excess thermal output will be transferred to the HBR system through the HX-HBR and then rejected by the heat balance radiator (HBR-1,2,3) on the flight deck.

The HBR system will be operated to maintain a CHPHW temperature to the CHP units of 180 °F.

CHCP Key/Main System Components

Components and equipment connected to or part of the CHPHW system are summarized as follows (additional discussion of components and operations are provided in the Sequences of Operations section):

**CHP-1,2,3:**

The three CHP units are Tecogen Inverde Ultra package cogeneration units with reciprocating engine prime movers (natural gas fueled). These units are rated at 100 kWe and produce 6.7 therms of recovered thermal energy per hour (670 MBH).

**P-CHPHW-1/2:**

CHCPHW flow is maintained by P-CHPHW1 or P-CHPHW2 at seasonal flow rates of 120 GPM heating and 200 GPM cooling. These pumps are redundant with VFD controllers and automatic duty cycling and backup transfer.

**HX-HTG:**

During the heating season, CHP thermal output is going to be used to heat the CHW system through HX-HTG. The manual seasonal bypass valve for HX-HTG, BPV-HTG, will be closed and all CHPHW will flow to HX-HTG. CHPHW flow to the HX-HTG will be controlled by CV-HXHTG based on a temperature sensor installed on the CHW leaving the HX-HTG. When heating loads are low, the CHW temperature leaving the HX-HTG will increase, resulting in the CV-HXHTG bypassing CHPHW around the HX-HTG as required for maintaining the CHW setpoint leaving the HX.

**CHILLER1:**

During the cooling season, CHPHW will flow to CHILLER1, a hot-water “fueled” absorption chiller. The manual seasonal bypass valve for the base load chillers, BPV-ABS, will be closed during the cooling season to force CHPHW supply flow to the absorption chiller. Note that the bypass valve for HX-HTG will be open and associated isolation valves on the HX will be closed to prevent flow to the HX-HTG during the cooling season.

INTREPID SEA, AIR, AND SPACE MUSEUM  
COMBINED HEAT AND POWER INSTALLATION

**HX-HBR:**

The HBR system and HX-HBR provide thermal rejection from the CHP hot water system to the heat balance radiators HBR-1/2/3 when the HBR system is enabled for operation and the CHP units are producing more thermal energy than required by the thermal loads. HX-HBR is designed to be able to reject the maximum total thermal output from the CHP units during electrical peaking mode operation. CHPW flow will be continuous through HX-HTG and heat rejection is enabled or disabled by control of HBR system components.

A basic site plan for The Intrepid Sea, Air, and Space Museum and a mechanical schematic for the CHP installation are included in the ATTACHMENTS section.

**CHP OUTPUT UTILIZATION**

Thermal Utilization

The CHW system circulates water between the CHP units and the supplemental heating/cooling equipment and the HVAC distribution systems and components. The CHP thermal output will be transferred to the CHW water either through the HX-HTG for heating or through CHILLER1, the hot-water absorption chiller. CHP thermal is the priority or baseload heating/cooling source with natural gas fueled condensing heaters and an electrical chiller to meet heating and cooling demand beyond the capacity of the CHP thermal output.

When necessary to enable standby electrical operation or otherwise desired (demand reduction periods), the CHP units will operate to meet electrical loads and may produce more thermal energy than is needed by the thermal loads. Excess thermal output will be transferred to the HBR system through the HX-HBR and then rejected by the heat balance radiator (HBR-1,2,3) on the flight deck.

Electrical Utilization

The electrical output of the CHP system will be utilized to run the CHP system auxiliary load and the facility load as shown in E-1.0. The units will be black start capable and will power critical loads as defined by the facility and design engineer when Coned power supply is down.

Electrical output from the CHP units is connected to the CHP electrical distribution bus/panel, which in turn supplies CHP auxiliary equipment and to the existing facility electrical distribution system. Normally the CHP units will operate in parallel with the utility electrical supply and the CHP unit electrical output will be connected to the facility electrical distribution system through protective relay systems, offsetting the electrical demand from the utility. In standby electrical operating mode, the CHP distribution bus/panel and selected facility loads will be isolated from the utility electrical system. The CHP units will operate to meet these loads with manual load shedding available if needed via existing switchgear.

INTREPID SEA, AIR, AND SPACE MUSEUM  
COMBINED HEAT AND POWER INSTALLATION

**NYSERDA MONITORING PLAN OVERVIEW:**

CHP System Schematic and NYSERDA Monitoring Points :

Mechanical drawings ISASM M-300 NMP and ISASM M-310 NMP included in the ATTACHMENTS section identify CHP system components, system connections and the collection points for NYSERDA Monitoring Plan data. Also included in the ATTACHMENTS is NYSERDA Monitored Points Table 1 listing the data points in the CHP installation. Table 1 lists the points that are being monitored, collection of the data, collection interval and accessing it and the monitoring equipment included in the design to collect the required data.

Data Logger and Data Processing:

*The following description of the data logger assumes that the project will contract with CDH energy to install the datalogger and carry out instrument terminations in the logger “box” and establishment of data transfer to the CDH data server.*

The M&V data will be collected by a datalogger installed by CDH Energy (NYSERDA M&V data integrator) location in the cogeneration room agreeable to the site and developer. The monitoring system panel is approximately 2 ft x 2 ft x 1 ft. The panel will be mounted near a 120 VAC power receptacle (it requires 1 amp or less). Wiring from the sensors to the logger must be installed by the project – CDH will not install these connections.

Readings for the installed instrumentation will be recorded by an Obvius AcquiSuite datalogger which samples all sensors approximately once per second and records one-minute totals (for pulse or digital sensors) or averages (for analog sensors). The one minute readings of heat recovery temperatures and flows will be used to provide an accurate calculation of heat transfer on the heat recovery loops, which are all continuous flow loops. The data will be downloaded from the datalogger once per day via an Internet connection provided by the Site. The data will be loaded into a database, checked for validity, and posted on the NYSERDA web site.

The datalogger will require a connection to the Internet. A dedicated static IP address is desired, but not required. If a dynamic IP address is used, the logger will upload data every night to the CDH Energy servers, but CDH personnel will not be able to access the logger for remote configuration purposes. The facility is expected to assist in providing a network connection for the datalogger. The site will be responsible for providing access to all areas necessary to complete the monitoring installation, as well as any access for return trips to verify sensors or service the monitoring system.

Data analysis and calculations will be carried out by CDH to determine the net power output of the system as well as the fuel conversion efficiency (FCE). CDH will post the performance data and analysis results to the NYSERDA CHP/DG website.

Monitoring Objectives:

The The Intrepid Sea, Air, and Space Musuem CHP monitoring plan has been designed to meet the Primary Monitoring Objectives as defined in Table 2 of the Monitoring and Data Collection Standard for Distributed Generation/Combined Heat and Power (DG/CHP) Systems manual. The monitoring objectives and associated data points from the The Intrepid Sea, Air, and Space Musuem CHP system are as follows:

INTREPID SEA, AIR, AND SPACE MUSEUM  
COMBINED HEAT AND POWER INSTALLATION

1) *Quantify variation of DG/CHP system fuel conversion efficiency over a wide range of annual operating conditions:*

A key objective of the NYSERDA M&V system is the collection of data required to determine the fuel conversion efficiency of the system (FCE). The fuel conversion efficiency of the CHP system, based on the lower heating value of the fuel, will be defined as:

$$FCE = \frac{Q_U + 3413 \times (W_{CHP} - W_{PAR})}{0.9 \times HHV_{gas} \times FG}$$

$Q_U$	Useful heat recovery from the CHP units
$W_{CHP}$	Gross CHP total electrical output
$W_{PAR}$	CHP parasitic electrical loads
$FG$	CHP fuel consumption (SCF)
$HHV_{gas}$	Higher heating value for natural gas (~1030 Btu/CF) Where 0.9 is the conversion factor between HHV and LHV

The FCE will be calculated by the CDH server for intervals (hourly, daily, monthly, etc) as requested by users of the CDH reporting website and based on the resolution of the gas metering data.

2) *Quantify variation of gross DG/CHP system power output:*

Metered/Measured inputs to data logger:

- CHP power output ( $W_{CHP1}$ ,  $W_{CHP2}$  and  $W_{CHP3}$ ) will be collected from the CHP unit controllers by MODBUS connection to the M&V logger.

$$W_{CHP} = W_{CHP1} + W_{CHP2} + W_{CHP3}$$

Gross Electrical efficiency will be calculated for a given time interval by converting the fuel input to the units and the electrical output into common units (BTU or kW). The electrical output divided by the fuel input in common units for a given time interval will provide the gross electrical efficiency.

Net electrical efficiency will be determined by subtracting the total parasitic loads (See part 2 below) from the gross electrical output and the dividing by the fuel input. These efficiencies will be determined for hourly, daily, and monthly intervals, with other intervals available as required for reporting. Unit conversions and efficiency calculations will be carried out external to the CHP data collection system.

3) *Quantify external parasitic loads:*

Metered/Measured inputs to data logger:

- WNET - the net electrical power to the MCC room distribution system (ship electrical loads) will be collected by the data logger from a WattNode in the the 3<sup>rd</sup> Deck MER.
- WCHLR2 – electrical power consumption by the supplemental electrical chiller, CHILLER2

INTREPID SEA, AIR, AND SPACE MUSEUM  
COMBINED HEAT AND POWER INSTALLATION

“Parasitic” electrical loads for the CHP systems are those electrical loads external to the CHP generator units which are required for the operation of the CHP system(s). These loads are supplied from the main CHP power panel DP-CHP in the 3<sup>rd</sup> Deck MER. Rather than measure each of the loads supplied by DP-CHP, the parasitic loads will be calculated as the difference between the gross CHP electrical output and WNET.

There are several loads on DP-CHP that are not actually parasitic loads including the supplemental electrical chiller and the supplemental heaters. The supplemental heater load is small enough to not have an impact on the efficiency calculations but the chiller will be a large electrical load. WCHLR2 will be collected from the chiller controller via MODBUS connection to the data logger (or using WattNodes if not available from chiller controller). The total parasitic load will be calculated as:

$$WPAR = (WCHP1 + WCHP2 + WCHP3) - (WNET + WCHLR2)$$

Parasitic power consumption will be determined for hourly, daily, and monthly intervals, with other intervals available as required for reporting.

- 4) *Quantify the daily, weekly, monthly, and annual variation of total facility power use (or power purchased from the utility) so that total actual utility costs can be determined:*

Monitoring of imported utility power (WMCC) will be achieved using data available from the Tru-Use™ electric load profiling system installed by DSMEA in the MCC room. The data from the Tru-Use™ monitor will be supplied to CDH by DSMEA – options and details for this transfer will be determined by DSMEA and CDH.

- 5) *Determine the thermal loads imposed on the CHP system by the facility (useful thermal output supplied to the facility) to measure the total CHP efficiency of the system on a daily, monthly, and annual basis; quantify the variation of these loads with ambient conditions and operating schedules;*

Metered/Measured inputs to data logger:

- FCHPHW - Flow (GPM) in the CHPHW main circulating loop will be collected as pulse outputs from the insertion flow meter M-CHPHW to the data logger
- THWS – temperature of the CHPHW leaving the CHP units will be collected by the data logger as RTD signal output from an an RTD in the CHPHW piping downstream of all the CHP connections
- THWR1 – temperature of the CHPHW after useful thermal loads will be collected by the data logger as RTD signal output from an an RTD in the CHPHW piping downstream of all the useful thermal load connections
- THWR2 – temperature of the CHPHW after HBR will be collected by the data logger as RTD signal output from an an RTD in the CHPHW piping downstream of all HBR connections

The total thermal output of the CHP installation ( $Q_T$ ) will be calculated as follows:

$$Q_T = FCHPHW \times (THWS - THWR2) \times 500 \text{ BTU/HOUR}$$



INTREPID SEA, AIR, AND SPACE MUSEUM  
COMBINED HEAT AND POWER INSTALLATION

Useful thermal output ( $Q_U$ ) delivered to facility loads is calculated as:

$$Q_U = FCHPHW \times (THWS - THWR1) \times 500 \text{ BTU/HOUR}$$

Heat rejected/dumped ( $Q_R$ ) is calculated as:

$$Q_R = FCHPHW \times (THWR2 - THWR1) \times 500 \text{ BTU/HOUR}$$

- 6) *Quantify the displaced fuel use on auxiliary equipment and systems to confirm the benefit of heat recovery:*

Displaced heating fuel use will be estimated based from CHP useful thermal output ( $Q_U$ ) and estimated fuel efficiency of the supplemental heaters:

$$\text{Fuel Offset} = Q_U \times (\text{Heater Efficiency}) / 100,000 \text{ Therms}$$

This calculation will be done during the heating season.

Displaced electrical consumption for the supplemental chiller during the cooling season is calculated as follows:

$$\text{Elect Offset} = [Q_U / 18,000] \times \text{Estimated Chiller SEER}$$

- 7) *Quantify the amount of available thermal energy that is unused or “dumped” by the CHP system in order to demonstrate a system “heat balance”.*

The CHP heat balance system (HBR), enables the CHP units to maintain electrical output when required, regardless of the thermal load in the facility. Under most operating conditions, the CHP units will be operated in thermal load following mode – CHP output will be reduced when thermal loads are low to minimize excess thermal output. There will be conditions such during CHP standby power operation where the CHP units must follow the electrical load. Under these conditions – referred to as “electrical following”, excess thermal output must be “dumped” to prevent overheating of the CHP units.

While in operation the CHP units will also continuously dump thermal energy from the inverter electronics package through the EFC (Electronics Fluid Cooling) system. Heat rejection from the EFC is relatively constant and will be included as a fixed amount of heat rejection for each CHP in service in a given hour.

Heat rejected/dumped ( $Q_R$ ) is calculated as:

$$Q_R = [FCHPHW \times (THW2 - THWR1) \times 500] + [Q_{EFC} \times \text{CHP units in service}] \text{ BTU/HOUR}$$

INTREPID SEA, AIR, AND SPACE MUSEUM  
COMBINED HEAT AND POWER INSTALLATION

Data Processing

Data analysis and calculations will be carried out by CDH to determine the net power output of the system as well as the fuel conversion efficiency (FCE). CDH will post the performance data and analysis results to the NYSERDA CHP/DG website.

Emissions Monitoring

As required and provided for by NYSERDA through contracted emissions analysis vendors, The Intrepid Sea, Air, and Space Museum CHP units will be available as pre-arranged with the facility for initial commissioning testing of the CHP unit emissions. Periodic re-evaluation will be supported as required and arranged for by NYSERDA.

INTREPID SEA, AIR, AND SPACE MUSEUM  
COMBINED HEAT AND POWER INSTALLATION

**ATTACHMENTS**

1. The Intrepid Sea, Air, and Space Museum CHP NYSEDA Monitoring Points Table1
2. CHP Mechanical Flow Diagram - ISASM M-300 NMP
3. CHP/Supplemental Heaters Gas Riser Diagram ISASM P-300 NMP
4. Electrical One Line Diagram - ISASM E-1.0 NMP

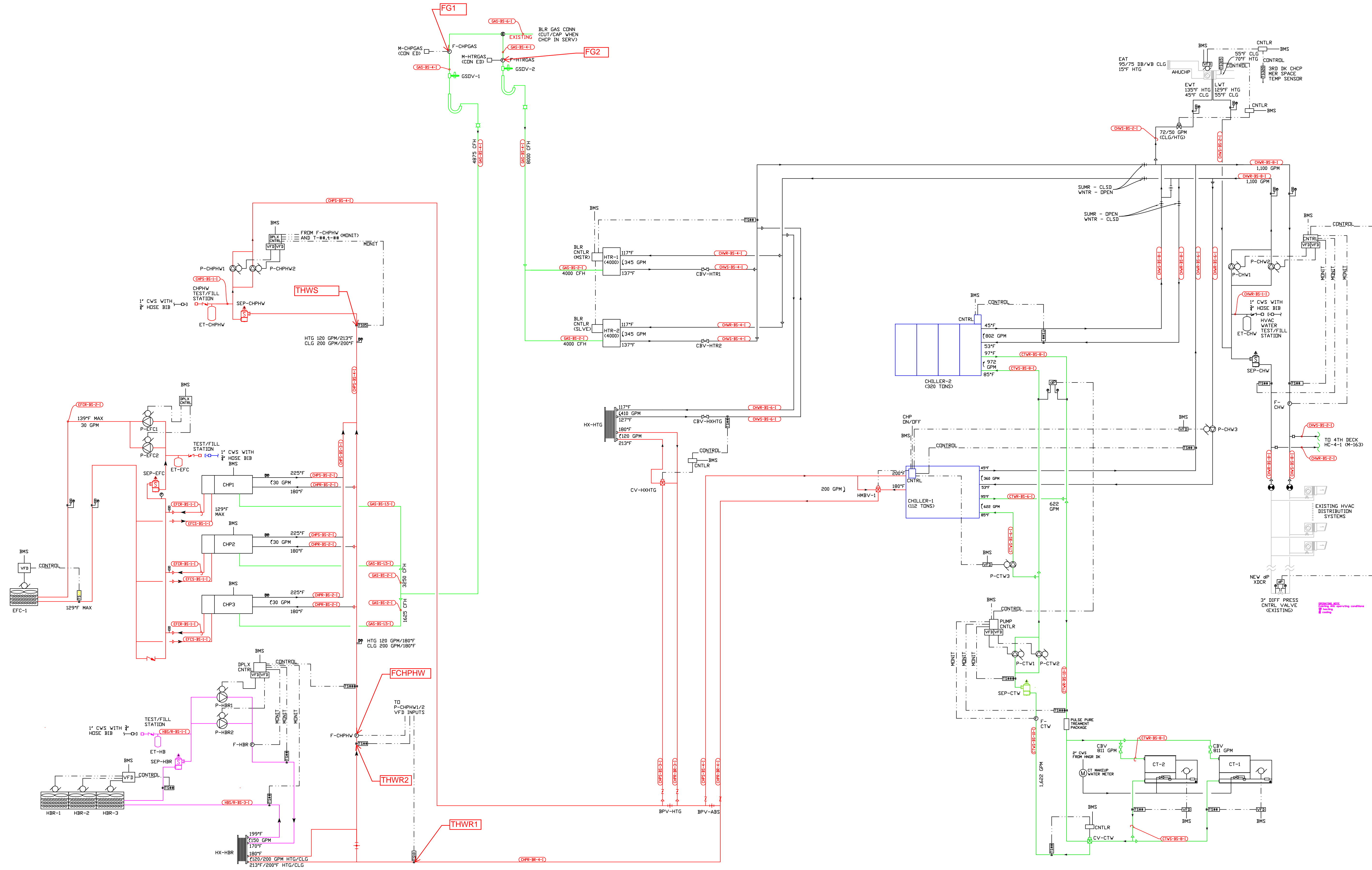

NOTES:

6		
5		
4		
3		
2		
1		
0	RELEASED FOR BIDS	3/12/14
NO.	REVISION DESCRIPTION	DATE

Professional Seal

**MECHANICAL**  
**DSM Engineering Associates PC**  
 "Low Carbon" Engineering Specialists  
 1363-26 Veterans Memorial Highway  
 Hauppauge, New York 11788  
 631-360-1208  
 WWW.DSMEA.COM

CONSULTANT DISCIPLINE

CONSULTANT DISCIPLINE

Project Name and Address  
**MECHANICAL**  
**MECHANICAL 1 LINE SCHEMATIC**  
**INTREPID MUSEUM**  
**CHCP INSTALLATION**  
**ONE INTREPID SQUARE**  
**EW YORK, NY 10036**  
 BLOCK: 1107 LOT: 30

Project No.	Drawing Number:
Date: 3/12/14	<b>M-300.00</b>
Scale: NTS	
Drawn by: JWA	Approved by: JWA
Sheet #: _____	of _____

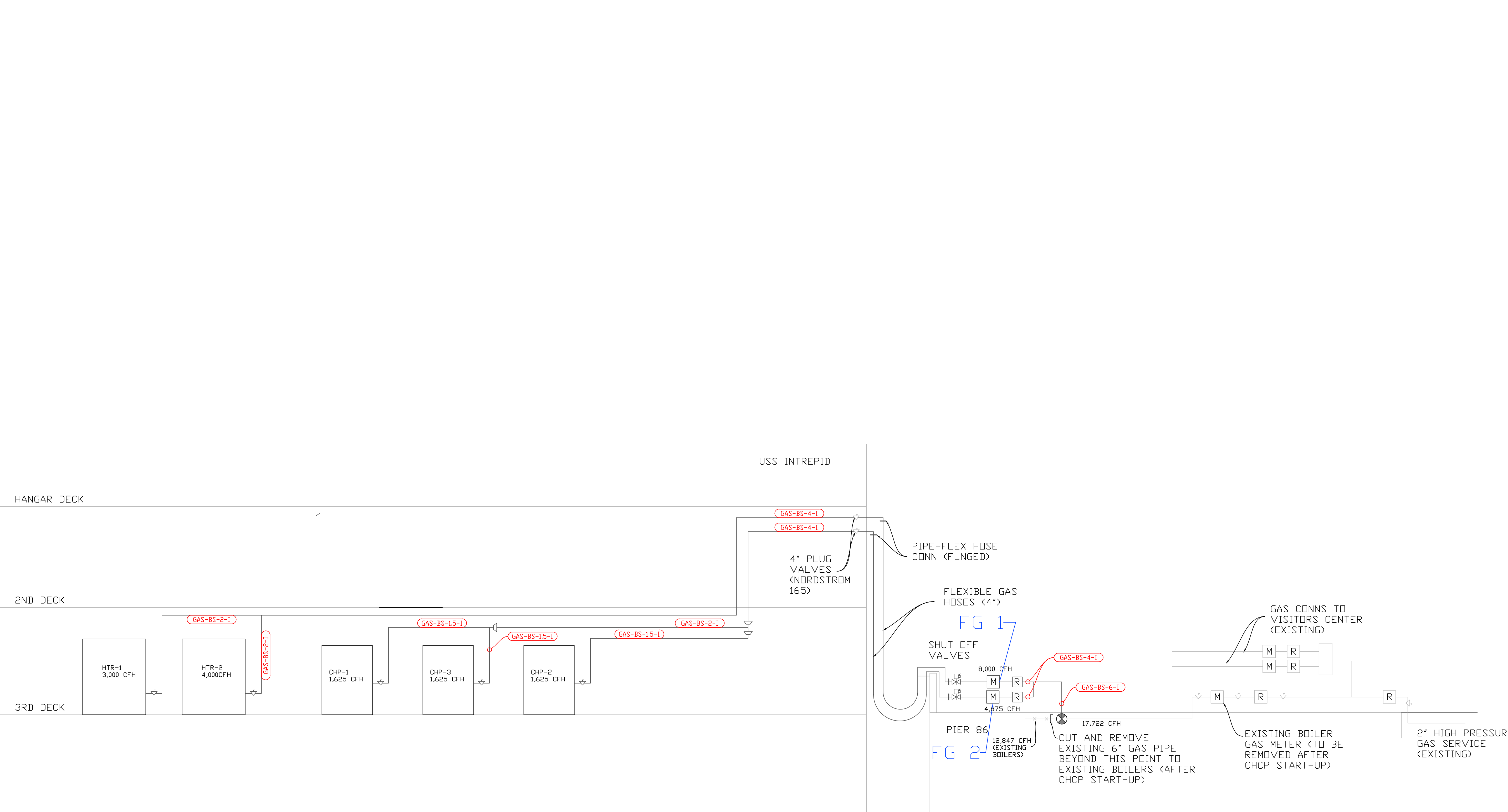

- NOTES:
- EXISTING REG/METER FOR BOILER WILL SUPPLY GAS DURING START-UP
  - EXISTING REG PRESS TO EXISTING BOILER APPROX 1 PSI, (TO REMAIN)
  - ADDD CON ED REGS TO DELIVER TO CHP/HEATERS/CHILLERS AT 14 IWC AT EQUIPMENT.
  - AFTER TRANSITION COMPLETED, CE TO INSTALL NEW METERS AND BILLING UNDER NEW ACCTS
  - GAS SERVICE CONNECTIONS TO VISITOR CENTER ARE NOT ALTERED BY PROJECT
  - GAS FLOW FOR 6" EXISTING INCLUDES EXISTING BOILER LOADS

6		
5		
4		
3		
2		
1		
0	DRAFT M&V SUBMISSION TO CDH	4/21/14
NO.	REVISION DESCRIPTION	DATE

Professional Seal

**MECHANICAL**  
**DSM Engineering Associates PC**  
 "Low Carbon" Engineering Specialists  
 1363-26 Veterans Memorial Highway  
 Hauppauge, New York 11788  
 631-360-1208  
 WWW.DSMEA.COM

CONSULTANT DISCIPLINE

CONSULTANT DISCIPLINE

Project Name and Address  
**MECHANICAL SCHEMATIC**  
**NAT GAS RISER DIAGRAM - M&V**  
**INTREPID MUSEUM**  
**CHCP PROJECT DEMONSTRATION**  
**ONE INTREPID SQUARE**  
**NEW YORK, NY 10036**  
 BLOCK: NA LOT: NA

Project No.	Drawing Number:
Date: 04/21/14	<b>P-300.00 NMP</b>
Scale: NTS	
Drawn by: JWA	Approved by: JWA
Sheet #:	of

**LEGEND**

- 27 Undervoltage Relay
- 32R Reverse Power Relay
- 42 Contactor
- 47 Phase Unbalance
- 50 Instantaneous Overcurrent
- 51 Time Overcurrent
- 59T AC Circuit Breaker
- 59 Overvoltage Relay
- 81 U/O Under/Over Frequency Relay
- 87 Differential Relay
- 89S Line Switch
- 89L Lockable Load Break Switch
- 89S-1 Circuit Breaker (Drawout)
- 89S-2 Circuit Breaker (Fixed Mount)
- Fused Outout
- Fused Disconnect
- Twin Fused Disconnect
- Disconnect Switch
- Contactor
- Shunt Trip Device
- Contactor Coil
- Open
- Metering Device
- Key Interlock
- N.O. Normally Open
- N.C. Normally Close
- O.C.S. Out Of Service
- AS/AF Amp Switch/Amp Fuse (Fused disconnect)
- AF/AT Amp Frame/Amp Trip (Circuit Breaker)
- Transformer
- Transfer Switch
- Inverter
- Cloud Indicates Proposed New Work
- Reactor

EXISTING  
NEW

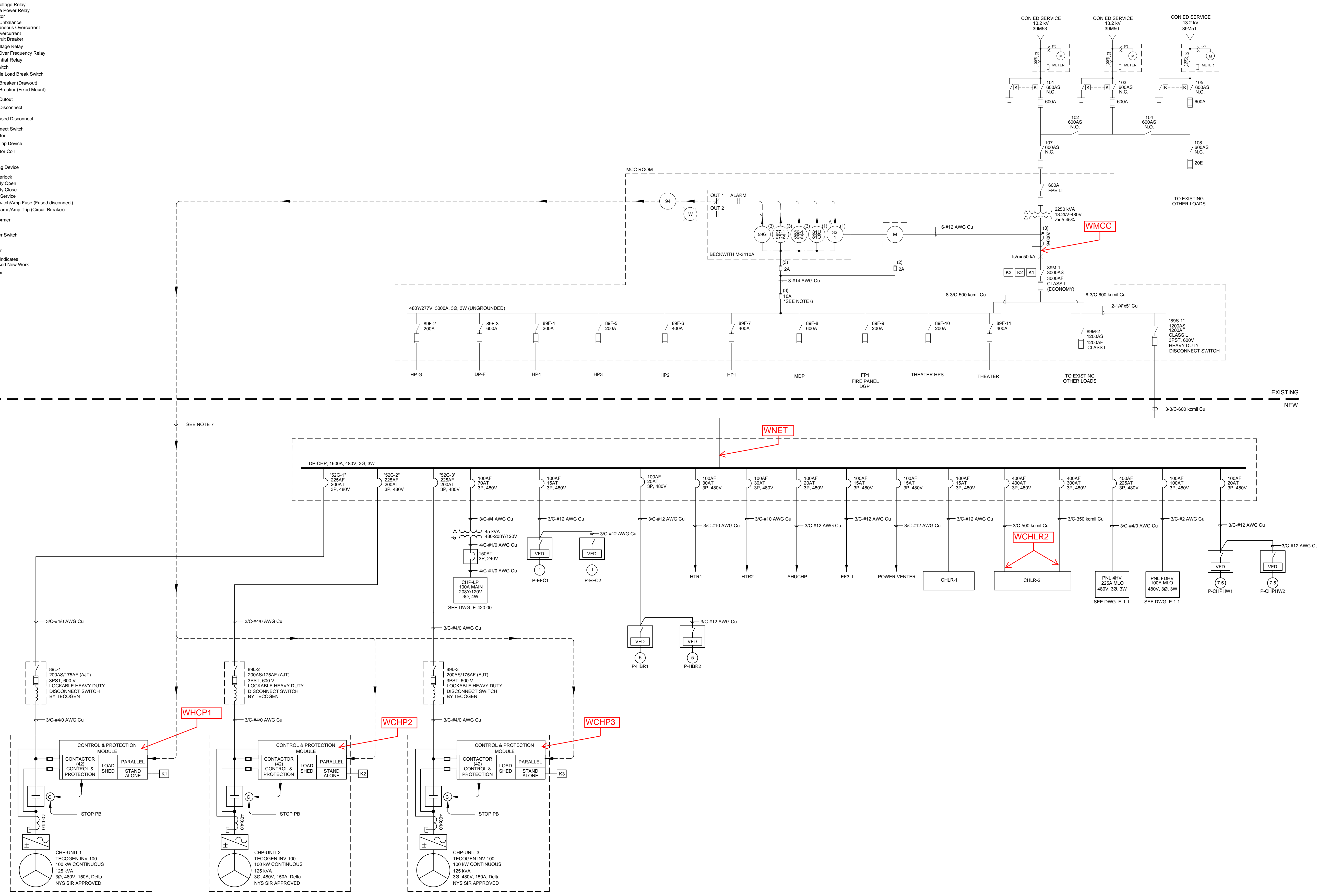

**NOTES:**

1. THIS PROJECT INSTALLS THREE NEW 100 kW CHP MODULES AND ALL NECESSARY EQUIPMENT TO PROVIDE PARALLEL OPERATION WITH CON ED SERVICE AND ISOLATED OPERATION IN THE EVENT OF A UTILITY OUTAGE.
2. ALL FUSES INDICATED WILL PROVIDE SELECTIVE COORDINATION, AND HAVE 200 KVAIC RATING.
3. THE GENERATORS ARE TO BE INSTALLED IN ACCORDANCE WITH NEW YORK STATE STANDARD INTERCONNECTION REQUIREMENTS AND CON ED E-2115. GENERATORS MAY RUN DURING UTILITY OUTAGE ONLY AFTER EXISTING 89M-1 SWITCH IS IN THE OPEN POSITION AND INTERLOCKS ARE IN PLACE.
4. UNLESS NOTED, ALL EQUIPMENT IS EXISTING, AND WILL REMAIN IN USE AND IS PREVIOUSLY APPROVED.
5. ALL ELECTRICAL CONSTRUCTION TO BE IN COMPLIANCE WITH 2008 NEC, AS AMENDED BY THE NYC DOB.
6. CABLE TAPS AND FUSING TO BE IN ACCORDANCE WITH SECTION 240 NFPA 70 (NEC).
7. CONTRACTOR TO MAKE CONNECTION TO RELAY AS REQUIRED, SEE DWG E-2.0 FOR ADDITIONAL INFORMATION.

**GRID ISOLATED MODE OPERATION PROCEDURE:**

- A. TO RUN THE INV-100 IN STAND ALONE MODE: ISOLATED FROM CON ED)
  1. REMOVE KEYS K1-K3 FROM 89M-1 SWITCH.
  2. OPEN PRE-SELECTED DISCONNECT SWITCHES TO ALLOW FOR PROPER LOAD SHEDDING.
  3. OPEN 89M-1.
  4. INSERT KEYS K1-K3 IN APPROPRIATE CHP UNITS.
  5. START UNITS 1-3 USING PROPER SYNCHRONIZING SEQUENCE.
  6. MONITOR LOADS.
- B. TO RETURN TO NORMAL: (PARALLEL TO CON ED)
  1. SHUT DOWN UNITS 1-3.
  2. REMOVE KEYS K1-K3 FROM CHP UNITS.
  3. INSERT KEYS K1-K3 IN 89M-1 SWITCH.
  4. CLOSE 89M-1 SWITCH.
  5. RESTORE ALL LOADS.
  6. RESTART CHP UNITS IN PARALLEL MODE.

**NOTES:**

0	RELEASE FOR BID	03/12/14
NO.	REVISION DESCRIPTION	DATE

Professional Seal

**DSM Engineering Associates PC**  
 "Low Carbon" Engineering Specialists  
 1363-26 Veterans Memorial Highway  
 Hauppauge, New York 11788  
 631-360-1208  
 WWW.DSMEA.COM

**ENGINEERING SERVICES, LLC**  
 15 TROWBRIDGE DRIVE  
 BETHEL, CT 06801  
 PHONE: (203) 798-0419 FAX: (203) 743-2325

Project Name and Address

**ONE-LINE DIAGRAM**

**INTREPID MUSEUM FOUNDATION**  
**ONE INTREPID SQUARE**  
**12th AVENUE & W 46th STREET**  
**NEW YORK, NEW YORK**

BLOCK: LOT:

Project No.	Drawing Number:
Date: <b>03/12/14</b>	<b>E-1.0</b>
Scale: <b>NONE</b>	Approved by: <b>BTC</b>
Drawn by: <b>KT</b>	Sheet #: of