

**MEASUREMENT AND VERIFICATION (M&V) PLAN
FOR
ROACH DAIRY FARM ANAEROBIC DIGESTER GAS (ADG) SYSTEM**

June, 2010

Submitted to:

New York State Energy Research and Development Authority
17 Columbia Circle
Albany, NY 12203-6399

Submitted by:

Roach Dairy Farm
2227 Stewart Corners Road
Scipio Center, NY 13147

Prepared by:

L&S Energy Services
58 Clifton Country Road, Ste 203
Clifton Park, NY 12065

PROJECT PARTICIPANTS

NYSERDA Project Manager	Kathleen O’Conner 17 Columbia Circle Albany, NY 12203-6399 518.862.1090 X 3422 kmo@nyserda.org
ADG-to-Electricity Program Contractor (the: “ADG Contractor”)	Roach Dairy Farm Contact: Tom Roach, Owner 2227 Stewart Corners Road Scipio Center, NY 113147 315.497.0182 Email: N/A
Project Manager	Steve McGlynn/Tad Young Cell: 315.730.4111 Email: stevemcglynn@verizon.net
Digester System Vendor/Designer	RCM Digesters International, LLC Contact: Angela McEliece P.O. Box 4716 Berkeley, CA 94704 510.834.4568 Email: amceliece@rcmdigesters.com
Engine/Generator/Gas Conditioning System Vendor	Martin Machinery/Gen-Tec Inc. Contact: Marcus Martin 39425 Excelsior Drive Latham, MO 65050 660.458.7000 Email: sales@martinmachinery.com Contact: Jason Hoover (Gen-Tec) Email: jhoover@Gen-Tec.com
NYSERDA Technical Consultant (TC)	L&S Energy Services Contact: Steve Atkins 58 Clifton Country Road Suite 203 Clifton Park, NY 123456 518.383.9405 X 220 Email: satkins@ls-energy.com
NYSERDA CHP Website Contractor (CHP Website Contractor)	CDH Energy Corp. Contact: Hugh Henderson PO Box 641 Cazenovia, NY 13035 315-655-1063 hugh@cdhenergy.com

Introduction

This plan describes the approach that will be used to monitor the performance of the anaerobic digester gas (ADG) system that is currently installed at Roach Dairy Farm, Scipio Center, NY to produce biogas and electricity. Biogas is used to fuel one engine-generator. The power produced will be consumed on site and/or exported back to the local utility. A monitoring system will be installed to measure and collect the data necessary to quantify the electric power produced and amount of biogas used by the engine-generator. The data will serve as the basis for payment of three (3) years of performance incentive payments, which have been applied for under a Standard Performance Contract with NYSERDA. The site will have one engine-generator with Total Contracted Capacity of 300 kW.

ADG System Description

The digester system at the farm was designed by RCM Digesters International, LLC. The power plant and gas conditioning equipment were provided by Martin Machinery. Gas and power metering were provided by Gen-Tec and Sage Metering Inc. The site will operate one 450 kW synchronous engine-generator with gas conditioning equipment, piping and controls installed in a designated building approximately 2000 ft from the digester. All the electrical loads at the farm have been consolidated into a single 3-phase, 1200 amp, 277/480 volt electrical service in order to accommodate the generator system. The engine-generator includes controls to synchronize the generator to the grid as well as a protective relay and controls to automatically isolate the units from the utility grid in the event of a utility power outage or other abnormal conditions. The generator is connected to the NYSEG distribution network through a solid-state bi-directional revenue meter. A 250 kW, diesel generator is connected to the farm electrical system through a 1200 A disconnect/transfer switch for use during power outages and genset maintenance.



Guascor 5FGLD 360 Engine-Generator and Heat Recovery Equipment



Digester



Biogas Flare



Scrubber and Effluent Tank (H₂S Removal)

Figure 1. Photos of System Components

Table 1. Biogas Systems at Swiss Valley Farms

Digester	Anaerobic digester mixed plug flow, floating polymer cover, heated
Feedstock	Dairy Manure, 1500 animal equivalents
Engine-Generators	(1) Guascor 5GLD 360 Engine-Generator PLC limited to 450 kW max. output on biogas 480 VAC, 3 phase

Biogas Conditioning	RCM hydrogen sulfide removal system/scrubber, gas cooler, particulate filter.
Engine Backup/startup Fuel	None
Heat Recovery Use	Digester, heifer barn, house, shop, utility room heating
Additional Heat Recovery	None

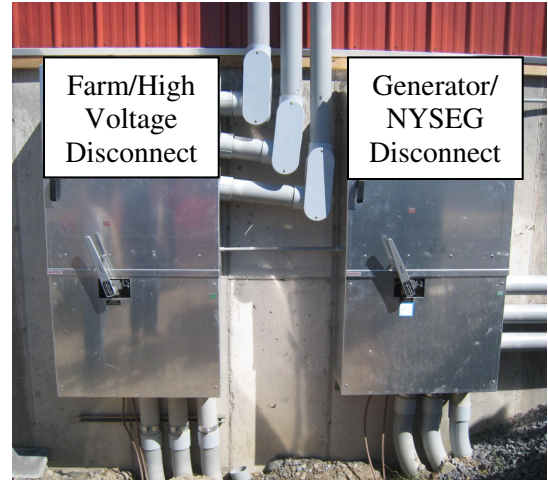
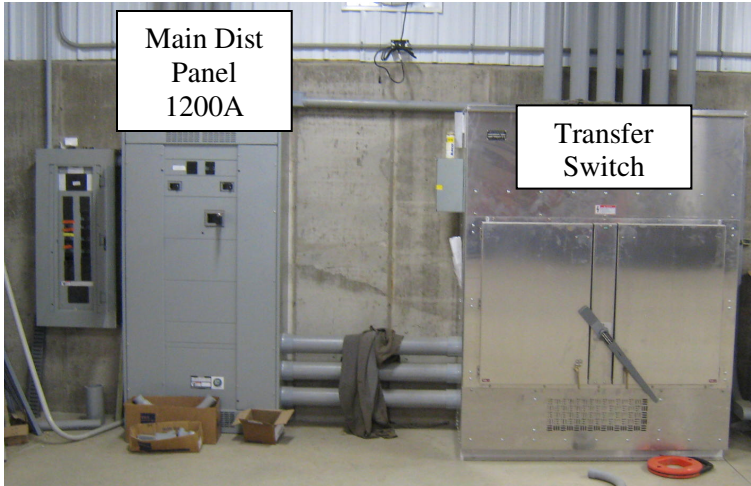

1200 Amp GFI Breaker/Transfer Switch

Figure 2. Photos of Electrical Panels



Intelisys Base Box and Digital Power Display



Integral Sage Mass Flow Meter (3)

Figure 3. Photos of Meters

Figure 4 schematically shows the biogas system and engine-generator. Figure 5 shows the single line electrical diagram for the system. Figure 6 shows the heat loop. Biogas from the digester is used in the engine-generator, flared or in a future auxiliary boiler. The biogas flare operates using a mechanically-actuated relief valve that vents biogas to maintain the gas input from the digester at or below 5 inches of water column (wc). Sage Prime metering devices measure gas flow to the flare (G1), the engine-generator (G2) and auxiliary boiler (G3).

Reduction in H₂S is accomplished by passing the bio-gas through a scrubber. The saturated gas is then passed through a gas cooler where water is condensed out in a water trap. The dehydrated and scrubbed gas is raised to a pressure of 38 inches wc by a gas blower and then supplied to the engine and auxiliary boiler as fuel.

Figure 6 schematically show the farm heating loop. Exhaust gas from the engine and hot engine coolant passes heat exchangers where the heat is transferred to a glycol loop. Heat in the glycol loop is transferred through a plate heat exchanger to the farm hot water heating loop. Hot water in the farm heating loop is used to heat the digester, shop, house, heifer barn, and utility room. When the engine temperature is too high and not enough heat is being extracted and used in the farm heating loop, the engine coolant is circulated through an external dump radiator. The water in the farm loop is continuously circulated. The water is circulated through and 1100 foot loop of 6" inch HDP piping to heat the digester. A shop, house and barn are also heated off of this loop using 400 feet of 1 inch, 100 feet of 1 inch, and 300 feet of 1.5 inch HDP piping respectively.

A dual fuel auxiliary boiler is installed in the heating loop for periods when the engine-generator is not in service or when there is a lack of biogas production. The auxiliary boiler can be fueled by either biogas or propane to provide the needed heat for the AD process.

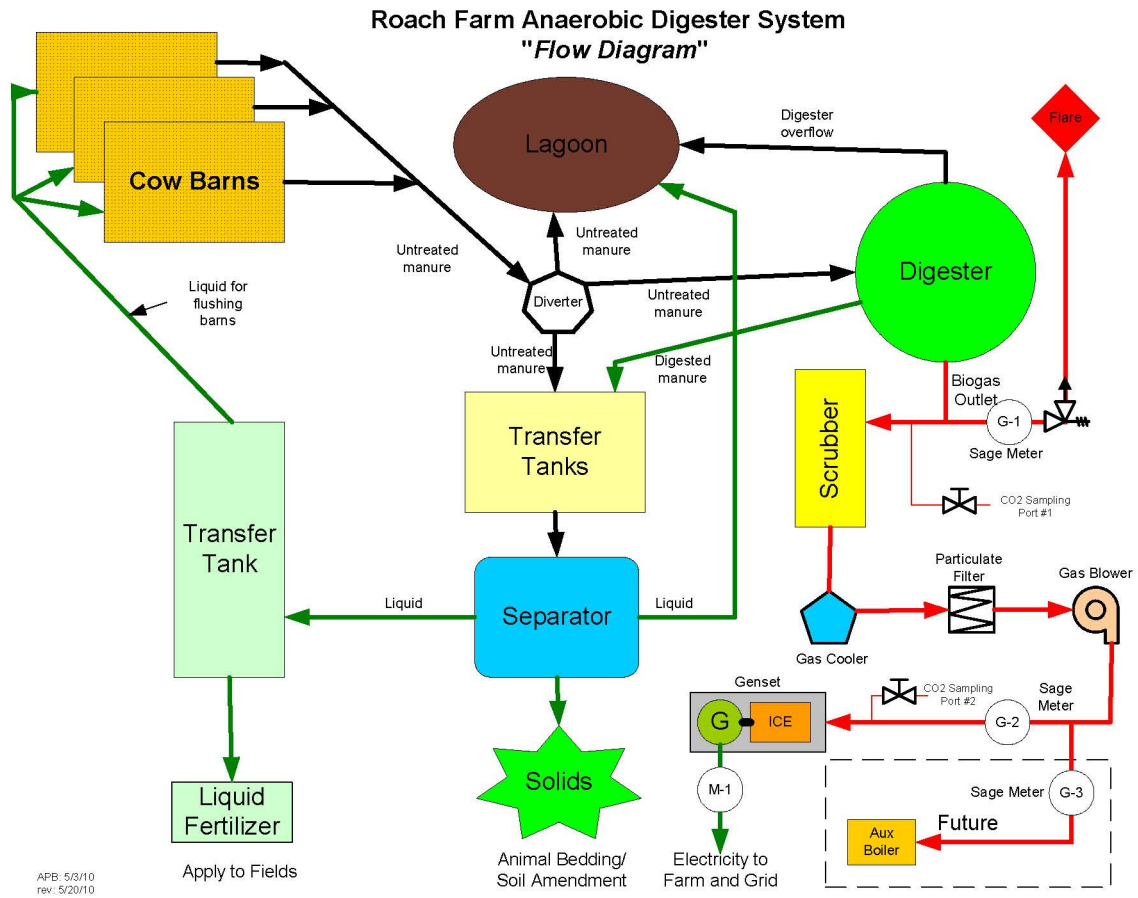
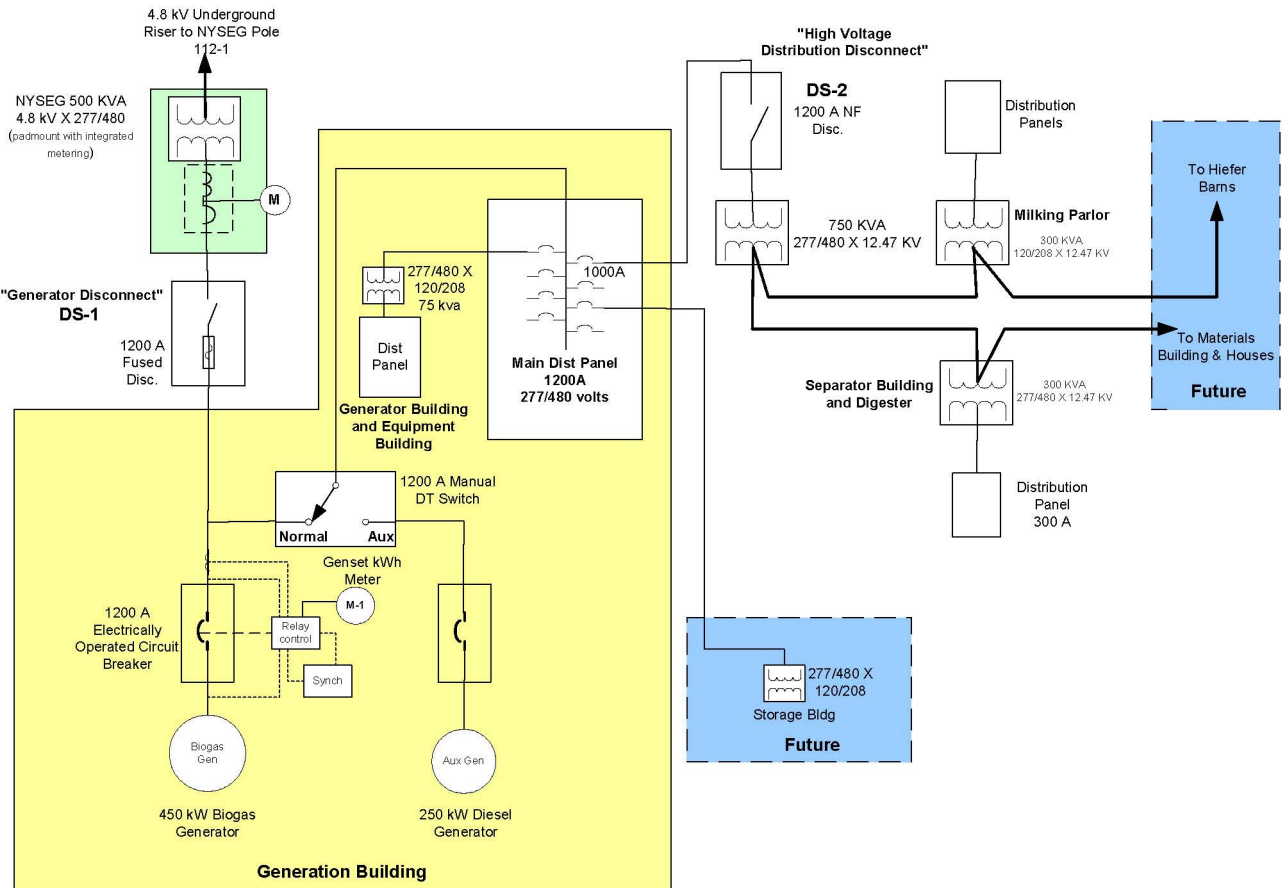

Figure 4. Schematic Biogas System

Roach Dairy Farm Electrical Distribution System



apb: 11.6.09
rev: 5.20.10

Figure 5. Single Line Electrical Diagram

Roach Farm Heat Loop Diagram

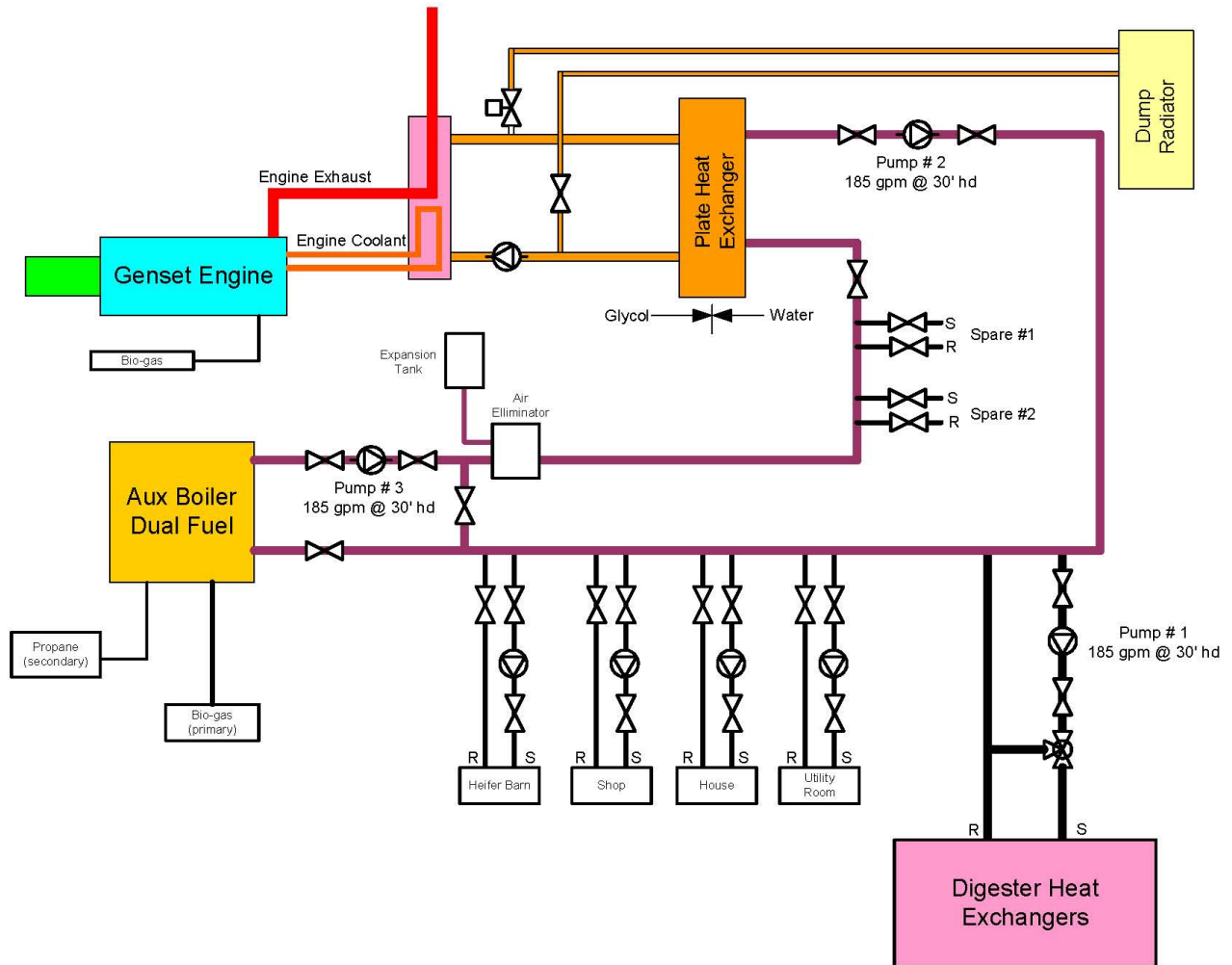

apb: 5.4.10

Figure 6. Heat Loop Diagram

Monitoring System Equipment, Installation, Operation, and Maintenance

Figure 4 shows the location of the meters used to measure fuel gas input to the flare (G1), engine-generator (G2), and future auxiliary boiler (G3). Figure 5 shows meter M-1 that is used to measure the kilowatts generated. Information on these data points is shown in Table 2.

Table 2. Monitored Points for ADG System

Point Type	Point Name	Description	Instrument	Engineering Units	Expected Range
Pulse	M1	Engine-Generator Power	Intelisys Base Box IS-NT-BB with LCD display	kW	0-500 kW
Pulse	G1	Engine Flare Flow	Sage Metering Inc. Model SIP-05-06-STCF05-DC24-DIG-GAS	ft ³	0 – 11000 ft ³ /h
Pulse	G2	Engine Biogas Flow	Sage Metering Inc. Model SIP-05-06-STCF05-DC24-DIG-GAS	ft ³	0 – 11000 ft ³ /h
Pulse	G3	Engine Biogas Flow	Sage Metering Inc. Model SIP-05-06-STCF05-DC24-DIG-GAS	ft ³	0 – 11000 ft ³ /h

The electrical output of the engine-generator will be measured with the Intelisys NT engine controller. The controller is installed in a stand alone cabinet on the side of the engine by the electrical contractor. It has an external graphical display which shows real time and total kWh. The controller will be installed according to the requirements in the “IntliGen^{NT}, Intelisys^{NT} Modular Gen-set Controller Operator Guide for SPI, SPtM, MINT, Cox” Software version IGS-NT-2.3. The sensor will be protected by a dedicated circuit breaker.

The biogas input to the engine-generator will be measured by a Sage Prime mass flow meter (G2) installed in-line just above the engine-generator. Two more Sage Prime mass flow meters will be installed. The flare meter (G1) will be installed above the RCM digester cabinet measures biogas flow to the flare and the auxiliary boiler gas flow meter (G3) will be installed next to the boiler.. The meters will be installed and maintained according to the “Sage Thermal Gas Mass Flow Meter Operations and Instruction Manual for Models SIP/SRP, Document 100-0001 Revision 05-SIP/SRG” as part of the engine generation equipment provided by Gen-Tec. A log of maintenance activities for the meters will be maintained at the site.

The lower heating value for the biogas is estimated to be 580 Btu/ft³, based on past measurements of the CO₂ content of the biogas taken by RCM. This value will be confirmed or adjusted based on weekly measurements of carbon dioxide using a Fyrite Gas Analyzer Model No. 10-5032 for CO₂ range 0-60%. Our farm program contractor, Tom Roach or other qualified staff will perform the CO₂ tests and log the results in the project log. This test is performed by taking a gas sample from the low pressure gas supply before it enters the gas conditioning equipment. The sampling point for untreated bio-gas is marked in Figure 4 as “CO₂ Sampling #1” and the sampling point for the scrubbed gas is labeled “CO₂ Sampling #2”

There is no backup/startup fuel for the engine-generator in this system.

Management of Monitoring System Data

We will perform the following quality assurance and quality control measures to ensure the data produced from our system accurately describes system performance.

On a daily basis, our equipment manager will perform inspections of the digester and engine-generator equipment and record findings into the project log.

On a weekly basis, the equipment manager will perform inspections of the M&V meter installations and complete the routine maintenance on the meters, noting any abnormalities or unexpected readings. We will also maintain a weekly log of the cumulative power generation (kWh) from meter M1 and gas flow (cf or ft³) recorded by the three Sage meters in the event that data transfer to the NYSERDA CHP Website fails or other anomalies occur.

On a monthly basis, our staff will review the data stored in the NYSERDA CHP Website (chp.nyserda.org) to ensure it is consistent with our observed performance of the ADG system and logged readings. We will use the website notification service provided at no charge by NYSERDA to alert us to any problems with the data between monthly data reviews. We will review the data using the *Monitored Data – Plots and Graphs* and *RPS: Customer-Sited Tier Anaerobic Digester Gas-to-Electricity Program NYSERDA Incentive Program Reports*, which can both be accessed through the NYSERDA CHP Website.

The CHP website consultant will install an Obvius AcquiLite datalogger to compile and log the data from the four monitoring points listed in Table 2 (see datalogger details in Appendix). The datalogger will be programmed to record the totalized data for each monitoring point for each 15-minute interval. A record of all multipliers and datalogger settings will be maintained. The datalogger will be located on the same wall as the Sage meters in the pole barn and will be connected to an uninterruptable power supply (UPS) to ensure the datalogger retains its settings and data in the event of a power outage. We will provide a phone line that will be used to communicate with the datalogger. We have confirmed that the NYSERDA CHP Website Contractor will call the datalogger nightly, via a phone modem link, to extract monitoring data from our ADG system and transfer the data to the NYSERDA CHP Website. If communications are lost, the Obvius datalogger is capable of holding at least 15 days of 15 minute interval data.

We understand that the CHP Website Contractor will take the data called from the data logger and evaluate the quality of the data for each hour of the day using range and relational checks. The expected ranges from the sensors, which will be used for the range checks, are listed in Table 2 under the “Expected Range” header. We understand that the relational check for new and existing generation will compare the kWh production data, and gas production data sets for each 15-minute interval for the engine-generator to ensure that both sets of meters always provide non-zero readings at the same time (e.g., a meter has failed). The value for M1 will be used to measure kWh production from the engine-generator. These values should not exceed the maximum range values and should be greater than zero. The value of G2 will be used for the total gas supplied to the engine-generator. We understand that only hourly data that passes all of these quality checks are used in the *RPS: Customer-Sited Tier Anaerobic Digester Gas-to-Electricity Program NYSERDA Incentive Program Reports*; however, all hourly data,

We will calculate monthly values for lower heating value of the biogas, total energy content of the biogas used, and any adjusted kWh production as follows.

Monthly Biogas Lower Heating Value

We will use the readings of CO₂ concentration in the biogas gathered weekly to estimate the average monthly Biogas Lower Heating Value using the following equation:

$$LHV_{biogas} = LHV_{methane} \cdot (1 - F_{CO_2})$$

where,

LHV_{methane}: lower heating value of methane (911 Btu/ft³ at standard conditions, 60 °F and 1 atm)
F_{CO₂}: fraction of biogas that is CO₂ (average of readings for each month)

Monthly Biogas Energy Content

We will calculate the average monthly Biogas Energy Content using the following equation:

$$Q_{biogas} = CF \cdot LHV_{biogas}$$

where,

CF: volume (ft³) of biogas in month

Reasonable Electrical Efficiency

The M&V Report will also provide a comparison of power output and fuel input for the engine to confirm their reasonableness. For instance, the electrical efficiency – measured as power output (kWh_{generator}) divided by the energy content of the fuel input (Q_{biogas}) in similar units and based on lower heating value – should be in the 25% - 35% range over any interval for the engine-generator.

Appendices

Cut sheets and Manuals for:

Sage Metering Inc. Model SIP-05-06-STCF05-DC24-DIG-GAS Mass Flow Meter
<http://www.sagemetering.com/specs/2ndgen/SIP-insertion-spec.pdf>

ComAP Intelisys NT Controller IS-NT-BB
<http://www.comap.cz/products/detail/intelisys-nt>

Fyrite Gas Analyzer
http://www.bacharach-inc.com/PDF/Brochures/fyrite_gas_analyzers.pdf
<http://www.bacharach-inc.com/PDF/Instructions/11-9026.pdf>